

ASYMPTOTICS OF CHARACTERS OF SYMMETRIC GROUPS AND FREE PROBABILITY

PIOTR ŚNIADY

ABSTRACT. In order to answer the question “*what is the asymptotic theory of representations of S_n* ” we will present two concrete problems. In both cases the solution requires a good understanding of the product (convolution) of conjugacy classes in the symmetric group and we will present a combinatorial setup for explicit calculation of such products. The asymptotic behavior of each summand in our expansion will depend on topology (genus) of a two-dimensional surface associated to some partitions and for this reason our method carries a strong resemblance to the genus expansion from the random matrix theory. In particular, non-crossing partitions and free probability play a special role.

1. WHAT IS THE ASYMPTOTIC THEORY OF THE REPRESENTATIONS OF THE SYMMETRIC GROUPS S_n ?

1.1. **(Generalized) Young diagrams.** Irreducible representations ρ^λ of the symmetric group S_n are in a one-to-one correspondence with *Young diagrams λ having n boxes*. An example of a Young diagram is presented on Figure 1.1. This figure also explains the notion of a *profile* of a Young diagram.

For a Young diagram with n boxes the area of the shaded region is equal to $2n$. After we shrink the geometric representation of this Young diagram by factor $\frac{1}{\sqrt{n}}$ we obtain a *generalized Young diagram* (cf Figure 1.2) for which the area of the shaded region is equal to 2. In the following we will compare the shapes of the Young diagrams only after such a rescaling.

Please note that the usual definition of a Young diagram λ says that it is a weakly decreasing sequence $\lambda_1 \geq \lambda_2 \geq \dots \geq \lambda_k$ of positive integers and the *generalized Young diagram* considered above do not fit into this category. Instead, any generalized Young diagram is by definition identified with its profile (i.e. a function $f : \mathbb{R} \rightarrow \mathbb{R}_+$ with some additional constraints which an interested Reader can easily guess) [Ker93].

1.2. **Example of a problem: characters of a large Young diagram.** Let (λ_n) be a sequence of Young diagrams such that λ_n has n boxes and that the shapes of the Young diagrams λ_n converge (after rescaling) to some generalized Young diagram.

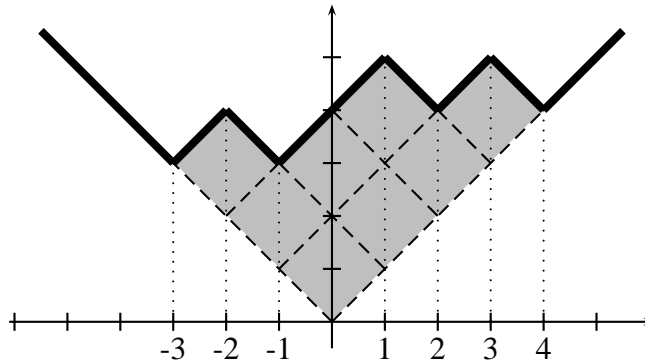

FIGURE 1.1. Graphical representation of a Young diagram $\lambda = (4, 3, 1)$ with 8 boxes. The thick ragged line is called the *profile* of a Young diagram.

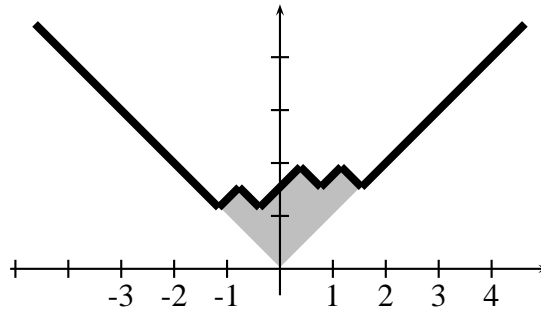

FIGURE 1.2. The Young diagram from Figure 1.1 after rescaling. The area of the shaded region is equal to 2.

What can we say about the characters of the corresponding irreducible representations

$$\chi^{\lambda_n}(\pi)$$

in the limit $n \rightarrow \infty$, where π is a fixed permutation?

1.3. Example of a problem: what was the shape of the pile of stones?

For an integer $n \geq 1$ we consider a Young diagram ν with a shape of a $n \times n$ square. A *standard Young tableaux* is a filling of this Young diagram with numbers $1, \dots, n^2$ such that the numbers increase along the diagonals \nearrow, \nwarrow from the bottom to the top, cf Figure 1.3 (left). We can think that a Young diagram is a *pile of stones* and the Young tableau is the order in which the stones are placed.

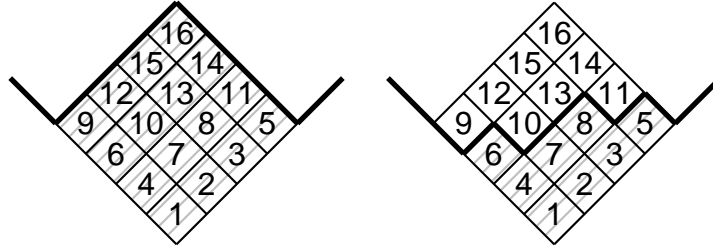

FIGURE 1.3. On the left: example of a standard Young tableaux of a square shape. On the right: the Young diagram resulting from this tableaux by removing the half of the boxes with the biggest numbers.

Let $0 < \alpha < 1$ be fixed; we remove from a randomly chosen standard Young tableaux all boxes with numbers bigger than αn^2 , cf Figure 1.3 (right). What is the shape of the resulting Young diagram λ with αn^2 boxes, when $n \rightarrow \infty$? In other words: *What was the shape of this pile of stones in the past* [PR04]? This problem is equivalent to the study of *the restriction of representations*: the random Young diagram λ described above has the same distribution as a randomly chosen summand in the decomposition of $\rho = \rho^\vee \downarrow_{S_{\alpha n^2}}^{S_{n^2}}$ into irreducible components.

1.4. Conclusions from the above examples. In principle, for any question concerning representations of S_n there is a well-known answer given by some *combinatorial* algorithm. However, when $n \rightarrow \infty$ such *combinatorial* answers are too complicated to be useful. We need more analytic methods and—as we shall see—Kerov’s transition measure is such an appropriate analytic tool.

The second problem (Section 1.3) indicates another phenomenon: in the asymptotic theory of representations some questions are of *statistical* flavor from the very beginning.

1.5. Kerov’s transition measure. It was an idea of Kerov [Ker93] to associate to a Young diagram λ its *transition measure* μ_λ which is a certain probability measure on \mathbb{R} . The transition measure encodes the information about the shape of the Young diagram in a very compact and efficient way and it can be defined in (at least) four equivalent and interesting ways. Below we present just one of them (which is due to Biane [Bia98]).

We consider a matrix J , the entries of which belong to $\mathbb{C}(S_n)$, the symmetric group algebra:

$$J = \begin{bmatrix} 0 & (1,2) & \dots & (1,n) & 1 \\ (2,1) & 0 & \dots & (2,n) & 1 \\ \vdots & \vdots & \ddots & \vdots & \vdots \\ (n,1) & (n,2) & \dots & 0 & 1 \\ 1 & 1 & \dots & 1 & 0 \end{bmatrix} \in \mathcal{M}_{n+1}(\mathbb{C}) \otimes \mathbb{C}(S_n).$$

Except for the last row, the last column and the diagonal, the entry in the i -th row and the j -th column is equal to the transposition interchanging i and j . For a Young diagram λ we apply the irreducible representation ρ^λ to every entry of J and denote the outcome by $\rho^\lambda(J) \in \mathcal{M}_{n+1}(\mathbb{C}) \otimes \mathcal{M}_k(\mathbb{C}) = \mathcal{M}_{(n+1)k}(\mathbb{C})$.

The *transition measure* of λ (denoted μ^λ) is defined to be the spectral measure of the matrix $\rho^\lambda(J)$; in other words

$$(1.1) \quad \mu^\lambda = \frac{\delta_{\zeta_1} + \dots + \delta_{\zeta_l}}{l},$$

where ζ_1, \dots, ζ_l are the eigenvalues of $\rho^\lambda(J)$ and δ_x denotes the Dirac measure at x . Since a compactly supported measure is determined by its moments this is equivalent with the requirement that

$$\int_{-\infty}^{\infty} x^k d\mu^\lambda(x) = \chi^\lambda(\text{tr } J^k).$$

The element $\text{tr } J^k \in \mathbb{C}(S_n)$ which appears in the right-hand side is called *k-th moment of the Jucys-Murphy element*.

Surprisingly, the definition of the transition measure can be naturally extended to generalized Young diagrams (which do not correspond to any irreducible representation). Furthermore, the transition measure behaves nicely with respect to the operation of rescaling.

2. HOW TO DEAL WITH CONJUGACY CLASSES?

2.1. Where the difficulty is hidden? The problem which we studied in Section 1.2 can be reformulated as follows: how to express a prescribed conjugacy class in $\mathbb{C}(S_n)$ (the calculation of the character on this class was our original goal) as a function of $(\text{tr } J^k)_{k \geq 1}$ (the character $\chi^\lambda(\text{tr } J^k)$ can be evaluated from (1.1))?

In Section 1.3 we studied the following problem: we know how to evaluate the characters of a reducible representation ρ (in our case: $\rho = \rho^\nu \downarrow_{S_{\alpha n^2}}^{S_{n^2}}$) on any conjugacy class and we ask statistical questions about the joint distribution of the random variables $\lambda \mapsto f_k(\lambda)$, where (f_k) is a family of some interesting functionals of the shape of a Young diagram and λ is a randomly

chosen Young diagram contributing to ρ . Via Fourier transform we can view each f_k as a central element of $\mathbb{C}(S_n)$ and therefore this question can be reformulated as follows: how to express the products $f_{k_1} \cdots f_{k_l} \in \mathbb{C}(S_n)$ as a linear combination of conjugacy classes?

To summarize very briefly: *the problem is how to work efficiently with conjugacy classes and their products.*

2.2. The main tool: partition-indexed conjugacy classes. Let $p = (p_1, \dots, p_l)$ be a sequence with $p_1, \dots, p_l \in \{1, \dots, n + 1\}$ and let π be a partition of the set $\{1, \dots, l\}$. We say that $p \sim \pi$ if for any $1 \leq i, j \leq l$ the equality $p_i = p_j$ holds if and only if i and j are connected by the partition π . We define

$$(2.1) \quad \Sigma_\pi = \frac{1}{n + 1} \sum_{i \sim \pi} J_{p_1 p_2} J_{p_2 p_3} \cdots J_{p_{l-1} p_l} J_{p_l p_1} = \sum_{\substack{i \sim \pi \\ i(l) = n+1}} J_{p_1 p_2} J_{p_2 p_3} \cdots J_{p_{l-1} p_l} J_{p_l p_1} \in \mathbb{C}(S_n).$$

We can show [Śni03b] that indeed the second and the third expression in (2.1) are equal and that all non-zero summands which contribute to (2.1) are conjugate and for this reason we call the central element Σ_π a *partition-indexed conjugacy class*.

Our main idea in our recent series of papers [Śni03b, Śni03a, Śni05] is that *partition-indexed conjugacy classes are a very good tool for studying questions concerning symmetric groups*. We will outline some arguments for it in the following.

2.3. The usual conjugacy classes. The above definition of partition-indexed conjugacy classes might sound quite strange since usually such conjugacy classes are defined in the following way: for integers $k_1, \dots, k_m \geq 1$ the conjugacy class $\Sigma_{k_1, \dots, k_m} \in \mathbb{C}(S_n)$ is given by [KO94, Bia03]:

$$(2.2) \quad \Sigma_{k_1, \dots, k_m} = \sum_{\alpha} (\alpha_{1,1}, \alpha_{1,2}, \dots, \alpha_{1,k_1}) \cdots (\alpha_{m,1}, \alpha_{m,2}, \dots, \alpha_{m,k_m}),$$

where the sum runs over all one-to-one functions

$$\alpha : \{ \{r, s\} : 1 \leq r \leq m, 1 \leq s \leq k_r \} \rightarrow \{1, \dots, n\}$$

and $(\alpha_{1,1}, \alpha_{1,2}, \dots, \alpha_{1,k_1}) \cdots (\alpha_{m,1}, \alpha_{m,2}, \dots, \alpha_{m,k_m})$ is a product of disjoint cycles.

In other words, we consider a Young diagram (k_1, \dots, k_m) and all ways of filling it with the elements of the set $\{1, \dots, n\}$ in such a way that no element appears more than once. Each such a filling can be interpreted as a

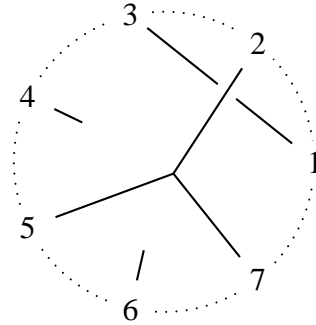

FIGURE 2.1. A graphical representation of a partition $\pi = \{\{1, 3\}, \{2, 5, 7\}, \{4\}, \{6\}\}$.

permutation when we treat rows of the Young tableau as disjoint cycles. It follows that each summand in (2.2) is a permutation with cycles of length k_1, \dots, k_m and additionally with $n - (k_1 + \dots + k_m)$ fix-points.

2.4. A concrete form of the partition-indexed conjugacy classes. Now a question arises how to relate the two kinds of conjugacy classes considered above and we will present a solution to this problem in this section.

It is convenient to represent partitions graphically, as it is shown on Figure 2.1. If we draw a partition with a very fat pen and take the boundary of this picture we obtain a fattened partition, as it is shown on the Figure 2.2 (left). We will use the convention that every vertex of the original partition is split into two *half-vertices*. The lines of this fat partition are equipped with the arrows which correspond to a counterclockwise orientation of the original blocks of the partition π and we added some extra lines at the boundary which connect elements 3 to 2', 2 to 1',... In order to bring some order we ask a British policeman to organize a traffic circle so that every line must turn clockwise around the central disc, as it presented on Figure 2.2 (right). (French policemen are better in arranging such a *rond point* but unfortunately they prefer a counterclockwise traffic)

In this way we obtained a number of loops L_1, \dots, L_r : for a loop L we count the number V of vertices visited (attention! half-vertex is counted as $\frac{1}{2}$ of a vertex) and the winding number W of a loop around the British policemen in the center. In the example from Figure 2.2 (right) there are two loops: $1 \rightarrow 7' \rightarrow 2 \rightarrow 1' \rightarrow 3 \rightarrow 2' \rightarrow 5 \rightarrow 4' \rightarrow 4 \rightarrow 3' \rightarrow 1 \rightarrow \dots$ ($V = 5$ vertices visited and $W = 3$ winds) and $7 \rightarrow 6' \rightarrow 6 \rightarrow 5' \rightarrow 7 \rightarrow \dots$ ($V = 2$ vertices visited and $W = 1$ wind).

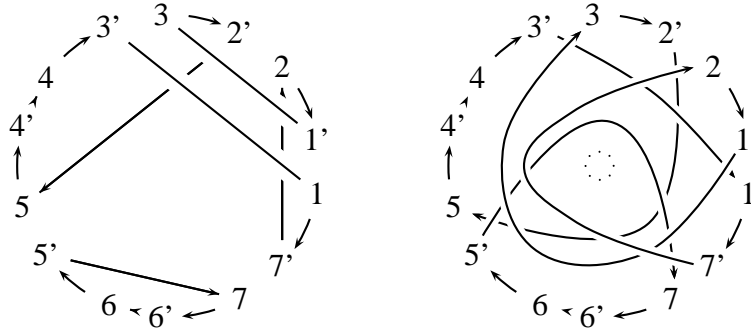

FIGURE 2.2. On the left: a fat partition corresponding to the partition π from Figure 2.1. On the right: a version of this figure in which all lines wind clockwise around the central disc.

We prove [Śni03b] that the relation between conjugacy classes Σ_π defined in 2.1 and the conjugacy classes Σ_{k_1, \dots, k_m} defined in 2.2 is given explicitly by

$$\Sigma_\pi = \Sigma_{V_1 - W_1, \dots, V_r - W_r}.$$

2.5. Products of conjugacy classes. The first advantage of the partition-indexed conjugacy classes is that their product can be easily expressed combinatorially [Śni03b]. To be precise for any partition π_1 of a set $\{1, \dots, l_1\}$ and any partition π_2 of a set $\{l_1 + 1, l_1 + 2, \dots, l_1 + l_2\}$

$$(2.3) \quad \Sigma_{l_1} \Sigma_{l_2} = \sum_{\pi} \Sigma_\pi,$$

where the sum runs over all partitions π of the set $\{1, \dots, l_1 + l_2\}$ such that

- any elements $a, b \in \{1, \dots, l_1\}$ are connected by π if and only if they are connected by π_1 ,
- any elements $a, b \in \{l_1 + 1, \dots, l_1 + l_2\}$ are connected by π if and only if they are connected by π_2 ,
- elements l_1 and $l_1 + l_2$ are connected by π .

2.6. Moments of Jucys-Murphy elements. The second advantage of the partition-indexed conjugacy classes is that they can be used to express easily the moments $M_k = \text{tr } J^k$ of Jucys-Murphy elements [Śni03b]:

$$(2.4) \quad M_k = \text{tr } J^k = \sum_{\pi} \Sigma_\pi,$$

where the sum runs over all partitions π of the set $\{1, \dots, k\}$.

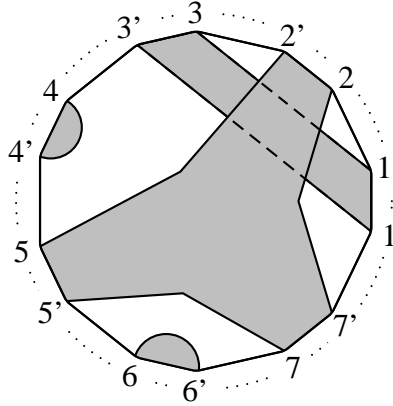

FIGURE 2.3. The first collection of discs for partition π from Figure 2.1.

2.7. Genus expansion. Equations (2.3) and (2.4) give us exact formulas, nevertheless in the asymptotic theory of representations of symmetric groups S_n we are rather interested in approximate formulas which hold asymptotically as $n \rightarrow \infty$. For this reason we define a filtration on the algebra of conjugacy classes [IK99, IO02, Śni04] by

$$\deg \Sigma_{k_1, \dots, k_l} = (k_1 + 1) + \dots + (k_l + 1).$$

We consider a large sphere with a small circular hole. The boundary of this hole is the circle from Figure 2.1. Let us draw the blocks of the partition π with a fat pen; in this way each block becomes a disc glued to the boundary of the hole, cf Figure 2.3.

After gluing the first collection of discs, our sphere becomes a surface with a number of holes. The boundary of each hole is a circle and we shall glue this hole with another disc. Thus we obtained an orientable surface without a boundary. We call the genus of this surface the genus of the partition π and denote it by genus_π .

The following result was proved in our previous work [Śni03b]: for any partition π of an n -element set

$$(2.5) \quad \deg \Sigma_\pi = n - 2 \text{genus}_\pi.$$

In other words: the dominating contribution in the asymptotic problems will come from the partitions with the minimal possible genus. Similar formulas involving surfaces appear in the random matrix theory.

3. OK, SO WHERE IS FREE PROBABILITY THEORY?

Free probability of Voiculescu [VDN92] is a non-commutative probability theory in which the notion of independence was replaced by the notion of *freeness*. Free probability can be applied for example to describe asymptotic properties of some random matrices.

Speicher [Spe98] realized that the combinatorial structure behind freeness is the structure of *non-crossing partitions* [Kre72] and the corresponding *free cumulants*. We recall that a non-crossing partition is a partition with genus equal to 0. For a sequence (M_i) , called the sequence of moments, the corresponding sequence (R_i) of free cumulants is given implicitly by equations

$$(3.1) \quad M_k = \sum_{\pi} R_{\pi},$$

where the sum runs over all non-crossing partitions of the set $\{1, \dots, k\}$.

Please note the surprising similarity between equations (2.4) and (3.1). To the right-hand side of (3.1) contribute only non-crossing partitions and the first-order approximation of the right-hand side of (2.4) is given by non-crossing partitions. It follows that

$$(3.2) \quad \Sigma_k = R_{k+1} + (\text{lower degree terms}).$$

To conclude: *free cumulants of the Jucys-Murphy element (or, equivalently, of the corresponding transition measure) are a very important tool for study of asymptotical theory of representations* and there are two reasons for it. Firstly, free cumulants are homogenous in a sense that they behave nicely with respect to rescaling of a generalized Young diagram and therefore it is easy to understand their asymptotic behavior. Secondly, the relation (3.2) between free cumulants and conjugacy classes is much simpler than the analogous relation between moments of the Jucys-Murphy element and conjugacy classes.

4. SOLUTIONS TO THE PROBLEMS

Methods presented in this article [Śni03b] can be used to attack the problems presented in Section 1 and we will present below the outcomes.

4.1. Problem from Section 1.2 revisited. Finally, the problem from Section 1.2 can be formulated as follows: *what is the relation between the conjugacy classes (Σ_k) and the free cumulants (R_k) ?* The first partial answer to this problem was given by Biane [Bia98] who proved (3.2) which can be regarded as a first-order approximation. In our recent article [Śni03a] we found explicitly the second-order asymptotics. Very recently Goulden and

Rattan [GR05] gave a complete solution to this problem (their solution uses very different methods).

4.2. Problem from Section 1.3 revisited. In our recent work [Śni05] we found a very large class of representations of S_n with a *approximate factorization of characters* and we proved that a shape of a randomly chosen Young diagram contributing to such representations concentrates around some limit shape (this part was already proved by Biane [Bia01]) and furthermore the fluctuations around this limit shape are Gaussian.

5. ACKNOWLEDGMENTS

Research supported by State Committee for Scientific Research (Komitet Badań Naukowych) grant No. 2P03A00723; by EU Network “QP-APPLICATIONS”, contract HPRN-CT-2002-00729; by KBN-DAAD project 36/2003/2004.

REFERENCES

- [Bia98] Philippe Biane. Representations of symmetric groups and free probability. *Adv. Math.*, 138(1):126–181, 1998.
- [Bia01] Philippe Biane. Approximate factorization and concentration for characters of symmetric groups. *Internat. Math. Res. Notices*, (4):179–192, 2001.
- [Bia03] Philippe Biane. Characters of symmetric groups and free cumulants. In Anatoly M. Vershik, editor, *Asymptotic Combinatorics with Applications to Mathematical Physics*, volume 1815 of *Lecture Notes in Mathematics*, pages 185–200. Springer, 2003.
- [GR05] I.P. Goulden and A. Rattan. An explicit form for Kerov’s character polynomials. Preprint, 2005.
- [IK99] V. Ivanov and S. Kerov. The algebra of conjugacy classes in symmetric groups, and partial permutations. *Zap. Nauchn. Sem. S.-Peterburg. Otdel. Mat. Inst. Steklov. (POMI)*, 256(Teor. Predst. Din. Sist. Komb. i Algoritm. Metody. 3):95–120, 265, 1999.
- [IO02] Vladimir Ivanov and Grigori Olshanski. Kerov’s central limit theorem for the Plancherel measure on Young diagrams. In S. Fomin, editor, *Symmetric Functions 2001: Surveys of Developments and Perspectives*, volume 74 of *NATO Science Series II. Mathematics, Physics and Chemistry*, pages 93–151. Kluwer, 2002.
- [Ker93] S. V. Kerov. Transition probabilities of continual Young diagrams and the Markov moment problem. *Funktsional. Anal. i Prilozhen.*, 27(2):32–49, 96, 1993.
- [KO94] Serguei Kerov and Grigori Olshanski. Polynomial functions on the set of Young diagrams. *C. R. Acad. Sci. Paris Sér. I Math.*, 319(2):121–126, 1994.
- [Kre72] G. Kreweras. Sur les partitions non croisées d’un cycle. *Discrete Math.*, 1(4):333–350, 1972.
- [PR04] Boris Pittel and Dan Romik. Limit shapes for random square Young tableaux and plane partitions. Preprint `arXiv:math.PR/0405190`, 2004.

- [Śni03a] Piotr Śniady. Free probability and representations of large symmetric groups. Preprint `arXiv:math.CO/0304275`, 2003.
- [Śni03b] Piotr Śniady. Symmetric groups and random matrices (the title of this preprint is tentative and might change). Preprint `arXiv:math.CO/0301299`, 2003.
- [Śni04] Piotr Śniady. Asymptotics of characters of symmetric groups and genus expansion. Preprint `arXiv:math.CO/041164`, 2004.
- [Śni05] Piotr Śniady. Gaussian fluctuations of characters of symmetric groups and of Young diagrams. Preprint `arXiv:math.CO/0501112`, 2005.
- [Spe98] Roland Speicher. Combinatorial theory of the free product with amalgamation and operator-valued free probability theory. *Mem. Amer. Math. Soc.*, 132(627):x+88, 1998.
- [VDN92] D. V. Voiculescu, K. J. Dykema, and A. Nica. *Free random variables*. American Mathematical Society, Providence, RI, 1992.

INSTITUTE OF MATHEMATICS, UNIVERSITY OF WROCLAW, PL. GRUNWALDZKI 2/4, 50-384 WROCLAW, POLAND

E-mail address: `Piotr.Sniady@math.uni.wroc.pl`

